

Reddi-Crate

Laminated
paper packaging

Reliable Performance

Superior strength offers protection throughout shipping and handling

Cost-effective Solution

Excellent replacement for traditional flat products and wooden crates

Application Versatility

Available with protective coatings for moisture resistance and corrosion protection

Highly Sustainable

Manufactured with 100% recycled materials and is 100% recyclable

Reddi-Crate

Laminated paper packaging



Reddi-Crate laminated paperboard packaging helps prevent product damage that can occur during shipping and handling. With a smooth surface and interior that is non-abrasive to products, Reddi-Crate can be used inside or outside a carton for product unitization and edge protection or helps to provide additional beam strength.

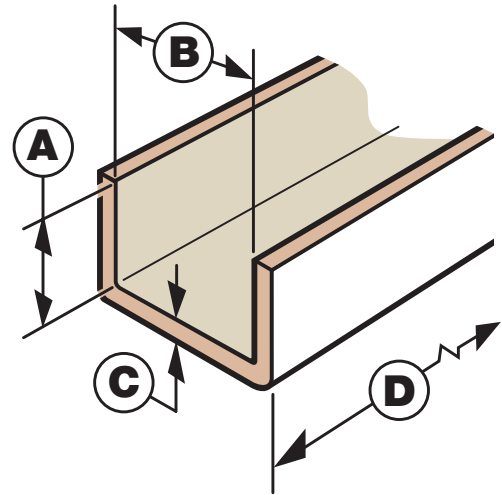
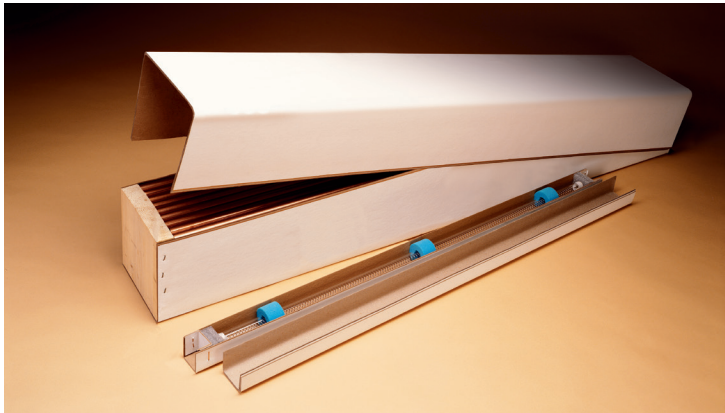

Features and benefits

- **Simplifies use**

Reddi-Crate's preformed profiles and two end closures form a shipping container that provides superior strength and protection throughout the transportation cycle.

- **Application flexibility**

Unlike traditional flat products, Reddi-Crate ensures maximum product protection for a wide range of products. It can be treated with protective coatings to provide moisture resistance and corrosion protection for those products exposed to humidity, condensation and other environmental conditions.

- **Enables product marketing**

Reddi-Crate can be printed, allowing for branding, product identification and point-of-sale merchandising.

Reddi-Crate Technical Specifications

A Leg Height	Available from 25-203 mm (1-8 in)
B Base Width	Available from 25-305 mm (1-12 in)
C Caliper	Available from 1.5-13 mm (.060-.500 in)
D Length	Available up to 16 m (53 ft)